



# ePicker

PICKING UP WHERE OTHERS LEAVE OFF



## PERFORMANCE STRADDLE STACKER

ESP15-157/177

**CAPACITY** 3000 lbs. at 24" load center

### PERFORMANCE

#### TRAVEL

Variable from 0 mph to 3.4 mph empty  
Variable from 0 mph to 3.1 mph loaded

#### LIFT

Up to 31 fpm empty. Up to 23 fpm loaded

#### LOWERING

Up to 25 fpm empty. Up to 33 fpm loaded

#### TIRES/WHEELS

#### DRIVE

9" x 3" polyurethane

#### DUAL LOAD

(2) 4" x 2.9" polyurethane

#### HYDRAULICS

Lift cylinder has hard chrome plated rods. Pump unit including motor, solenoid, gear pump, and pressure compensated lowering valve are mounted high in the power compartment for ease of service.

#### ELECTRICAL

24-Volt ZAPI AC inverter, travel control with matching drive motor provide high performance throughout the entire speed range. Travel speed remains constant relative to throttle position regardless of load. Separately fused power control circuits, quick disconnect EPD power cut off, and hour meter / battery discharge indicator combination gauge complete the system.

#### BATTERY

Compartment: 26.37" x 9.06" x open. Anderson 175 Red—A-11 Minimum battery weight 480 lbs. ePicker offers options for an industrial battery or a maintenance-free battery pack.

#### BRAKES

Electromagnetic brake is mounted on the motor armature shaft multiplying the braking power through the transmission.

Brake is applied when the control arm is in the vertical or horizontal handle position. Travel speed is reduced when forks are above 12" fork height. Neutral braking resists roll back on ramps.

#### TILLER ARM CONTROL

Travel, lift, and lower functions are located in the ergonomic operator handle. All operator controls are accessible without having to lift the hand from the handle.

Angle grips are designed to allow easy operation with either hand. Wrap around guard, reversing switch, thumb control, and horn are standard.

Top mounted tiller arm offers excellent operator comfort and minimum steering effort. Gas assisted spring gently returns handle to vertical position.

#### TRANSMISSION

Vertically mounted drive motor is direct mounted to gear housing. Oil bathed bevel gear drive train with tapered roller bearings transfers power to axle. State of the art optimized gear technology supplies advantages such as zero maintenance, low noise level, high efficiency and high performance.

#### FRAME AND MAST

Bolt-on high visibility mast, features I-beam construction, with lift cylinders positioned on the outer I-beam for best view through mast. Dual lifting chains. Adjustable straddle leg inside dimension (ID) can be set at 42" or 50". Four inch wide straddle legs = ID + 8" Class II ITA fork carriage with 36" tall load back rest. Forks are adjustable from 8" ID to 31" OD.

## BEARINGS

### DRIVE WHEEL

Tapered roller bearings sealed in oil bath.

### LOAD WHEELS

Sealed ball bearings.

## SERVICEABILITY

Removable two piece power head cover allows for easy maintenance and access to all vehicle components.

## STANDARD FEATURES

- Travel, lift, lower functions within operator handle
- Adjustable Straddle Legs
- Regenerative Braking
- Creep Speed Handle Control
- Gas Assist Spring Handle
- Low Battery Interrupt
- Hour Meter BDI Combo Gauge
- Key Switch

## OPTIONAL FEATURES

- 48" Tall Load Backrest
- Side-Shifting Fork Carriage
- 224AH 24V AGM Battery Pack with 110VAC Plug in Charger
- Industrial Battery
- Battery Compartment Rollers
- Class II 36" and 48" forks
- Traction Drive Tire - Poly
- Traction Drive Tire - Rubber

## DIMENSIONS

# PERFORMANCE STRADDLE STACKER

ESP15-157/177

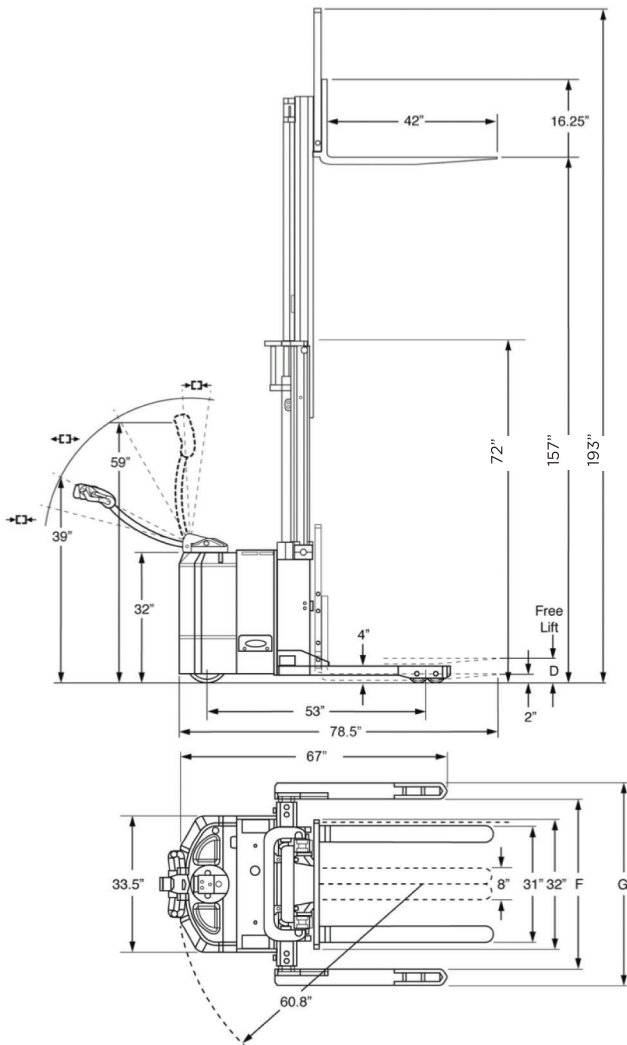

## AISLE GUIDE

### ESP15 - Right Angle Stacking

LOAD WIDTH	LOAD LENGTH		
	36"	40"	48"
36"	67.6"	67.6"	67.6"
40"	69.1"	69.1"	69.1"
48"	73.4"	73.4"	73.4"

For ease of use add 8" to aisle dimension listed. If sideshift option is used add 2".

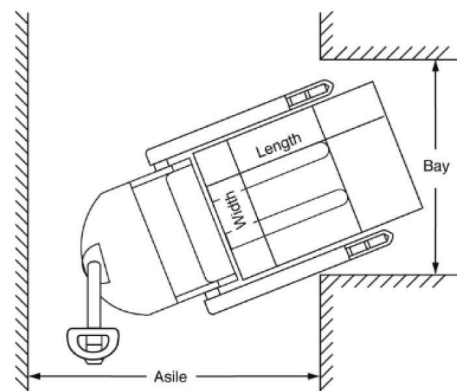

Aisle dimensions listed above assume the minimum bay width to be straddle OD plus 5" (2.5" on either side of straddle leg). Straddle OD is the load width plus 10". Track performance may vary due to application requirements and changes in model design.

MODEL#	MAST	LIFT HEIGHT	COLLAPSED HEIGHT	FREE LIFT	EXT HEIGHT w/ LBR	ADJUSTABLE STRADDLE LEGS 4" INCREMENTS		WEIGHT CHASSIS ONLY
		A	C	D	E	ID F	OD G	

### 3000 lbs. Capacity @ 24" Load Center ITA Class II Fork Carriage

ESP15-157	Three Stage	157	72	50	193	42-50	50-58	2444 lbs.
ESP15-177	Three Stage	177	80	58	213	42-50	50-58	2539 lbs.

\*Derates 1000 lbs. above 162"

<sup>2</sup> Minimum inside dimension (ID) 42" Outside dimension = inside dimension + 8"

<sup>3</sup> Estimated Shipping Weight Without Battery